



## 3" Single Port

Flanged CL 150 – 600  
Buttweld



3" Flowgrid® Valve with Series 20 Pilot

### SECTIONAL VIEW

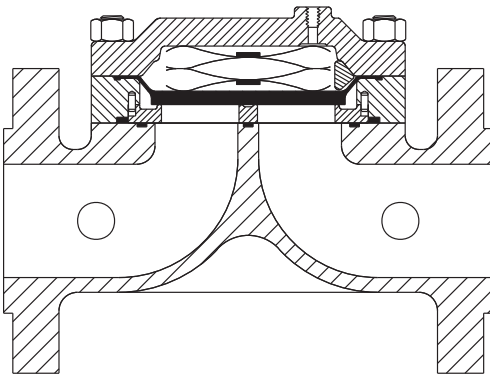

### OVERPRESSURE PROTECTION

The Flowgrid® Valve is bi-directional and has a full ANSI rating on both the inlet and outlet. Overpressure protection is required only if the pressure can exceed the flange or body rating.

The pilots, like most regulators, may have an outlet pressure rating lower than the inlet pressure rating. If this is the case then some external form of overpressure protection must be provided for the pilot.

Anytime the Flowgrid® valve or pilot system is exposed to pressure in excess of its rating it should be inspected for damage.

The 3" Flowgrid® Valve is an economical and easy to maintain pilot operated valve for both gas and liquid applications. The valve is designed to be used in conjunction with a self contained pilot control system. The low profile and easy in line maintenance make it ideal for skid mounted, vault, and enclosure installations.

### SPECIFICATIONS

<b>Size</b>	3"
<b>Body Style</b>	Single Port
<b>End Connections</b>	3" CL150, 300, 600 Flanged & Buttweld
<b>Temperature</b>	Working -20°F to 150°F Emergency -40°F to 175°F
<b>Max. Operating Differential</b>	800 psi
<b>Max. Emergency Differential</b>	1000 psi
<b>Min. Differential</b>	Refer to graph on page 2
<b>Cracking Differential</b>	Refer to graph on page 2
<b>Max. Inlet Pressure</b>	1480 psig*
<b>Outlet Pressure Range</b>	Limited By Pilot
<b>Flow Direction</b>	Bi-Directional**
<b>Body Taps</b>	Two 1/4" - 18NPT

\*Limited by pilot or flange rating

\*\*Reverse flow by changing pilot connections and reversing spring case

### MATERIALS OF CONSTRUCTION

<b>Body &amp; Spring Case</b>	ASTM A 216 GR WCB Carbon Steel
<b>Throttle Plate</b>	17 - 4PH Stainless Steel or A515 Carbon Steel with ENC Coating
<b>Diaphragm</b>	Nitrile/Nylon*
<b>O-Ring &amp; Seals</b>	Nitrile, Optional (Viton)
<b>Bolting</b>	ASTM A 193 GR B-7 or Equal
<b>Spring</b>	301 Stainless Steel

\*Refer to diaphragm selection chart on page 2

### STOCK NUMBERS

3" Single Port Valve	Stock #	Weight
<b>150# Flange</b>	FG-16	73 lbs.
<b>300# Flange</b>	FG-17	85 lbs.
<b>600# Flange</b>	FG-18	94 lbs.
<b>150-300# Buttweld</b>	FG-61	65 lbs.
<b>600# Buttweld</b>	FG-62	69 lbs.

## DIMENSIONS

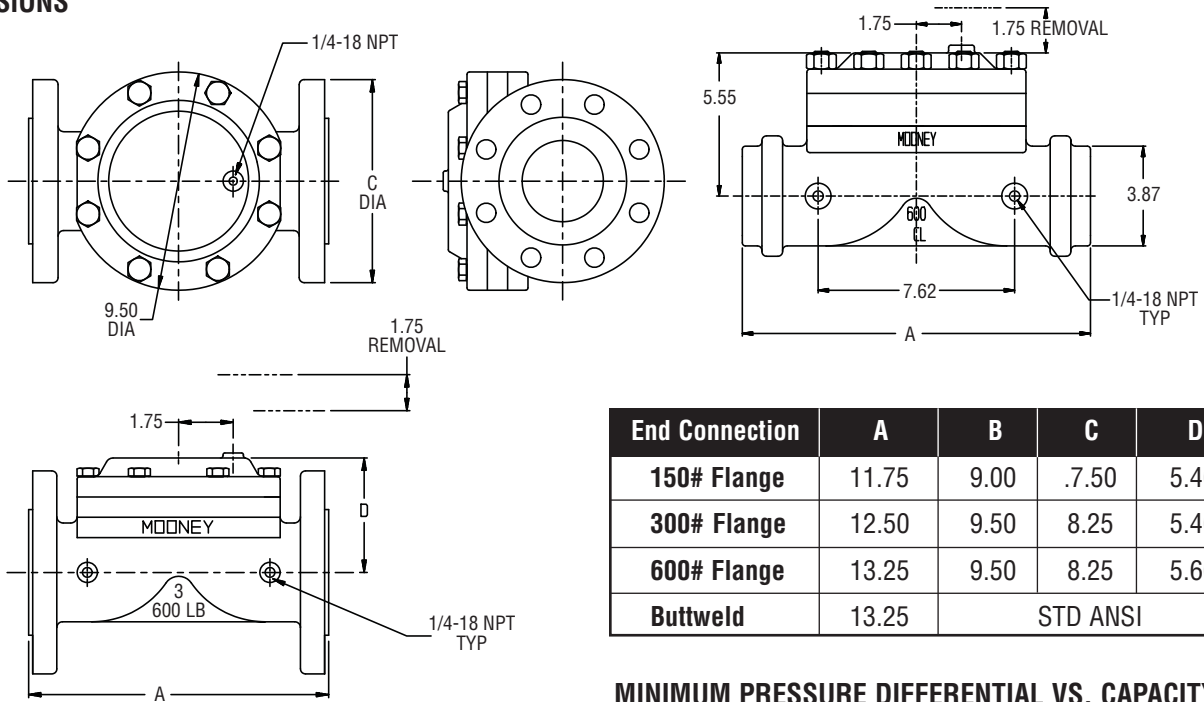

End Connection	A	B	C	D
150# Flange	11.75	9.00	.750	5.40
300# Flange	12.50	9.50	8.25	5.40
600# Flange	13.25	9.50	8.25	5.60
Buttweld	13.25	STD ANSI		

## FLOW COEFFICIENTS AND CONSTANTS

3" Single Port Valve				Swage Factor	
Percent Capacity	Cv	C1	Cg	1.5:1	2:1
100%	96	36	3450	0.98	0.95
75%	81	34	2730	1.00	1.00
50%	68	32	2150	1.00	1.00
35%	49	31	1530	1.00	1.00

NOTE: For Relief Sizing, add 5% to Cv and Cg Values

## MINIMUM PRESSURE DIFFERENTIAL VS. CAPACITY

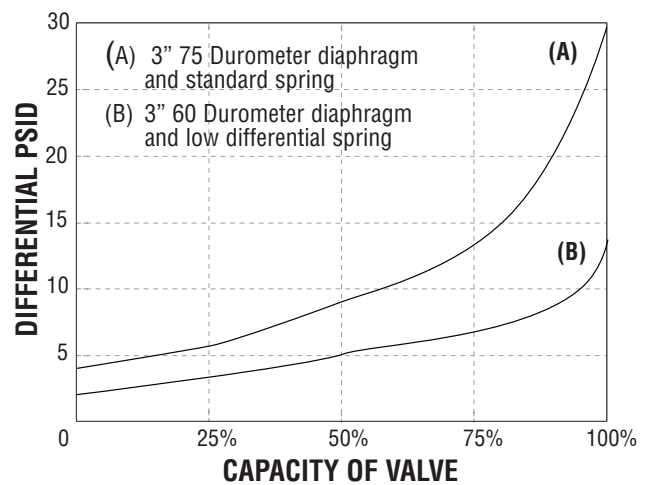

## DIAPHRAGM SELECTION

Compound	Temp. Range (Degrees F)	Maximum Differential	Characteristics	Recommended Applications
75 Duro	-20 to 150	1000 psid	Best All Around Material	60 psid to Max. Differential
60 Duro	-25 to 150	300 psid	Best Shutoff at Low Differential Pressure	Low Differential (100 psid or less) or Low Temperature
80 Duro High ACN	-5 to 175	1000 psid	Higher Abrasion and Swelling Resistance	High Differential (400 psid or higher) or Abrasive Conditions with Distillates
80 Duro Low ACN	-20 to 150	1000 psid	Higher Abrasion Resistance and Low Temperature Flexibility	High Differential (400 psid or higher) or Abrasive Conditions at Low Temperatures